

T&S BRASS AND BRONZE WORKS, INC.
 2 SADDLEBACK COVE / P.O. BOX 1088 / TRAVELERS REST, SC 29690
 PHONE 800-476-4103 FAX 864- 834-3518



REG.#A2601
 ISO #9002

Model No.

150A-CA

Item No.:

Job Name:

Architect/Engineer Approval:

Notes:

AB1953
 Compliant

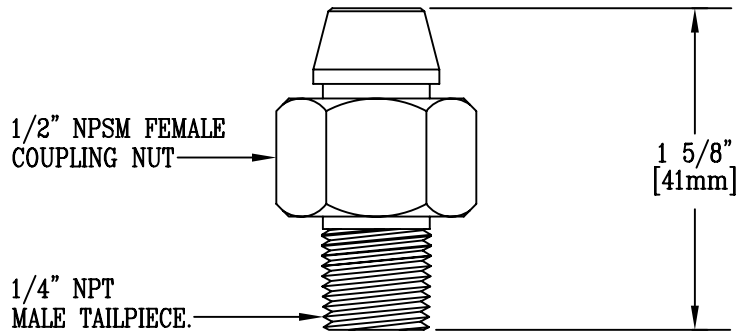

Product Description:

UNION COUPLING TAILPIECE

Drawn:

GEF

Checked

ARH

Scale:

1' = 1'

Approved

JHB

Date:

3/26/08