

*This Space for Architect/Engineer Approval*

Job Name \_\_\_\_\_ Date \_\_\_\_\_  
 Model Specified \_\_\_\_\_ Quantity \_\_\_\_\_  
 Customer/Wholesaler \_\_\_\_\_  
 Contractor \_\_\_\_\_  
 Architect/Engineer \_\_\_\_\_

*Available Options*

Model Suffix #	Description
<input type="checkbox"/> -5A	2.2 GPM VR Aerator
<input type="checkbox"/> -5B	0.5 GPM Aerator
<input type="checkbox"/> -5C	0.5 GPM VR Aerator
<input type="checkbox"/> -5D	2.2 GPM Laminar Flow
<input type="checkbox"/> -VR5C	Complete VR Pkg (0.5 GPM)
<input type="checkbox"/> -VR5A	Complete VR Pkg (2.2 GPM)

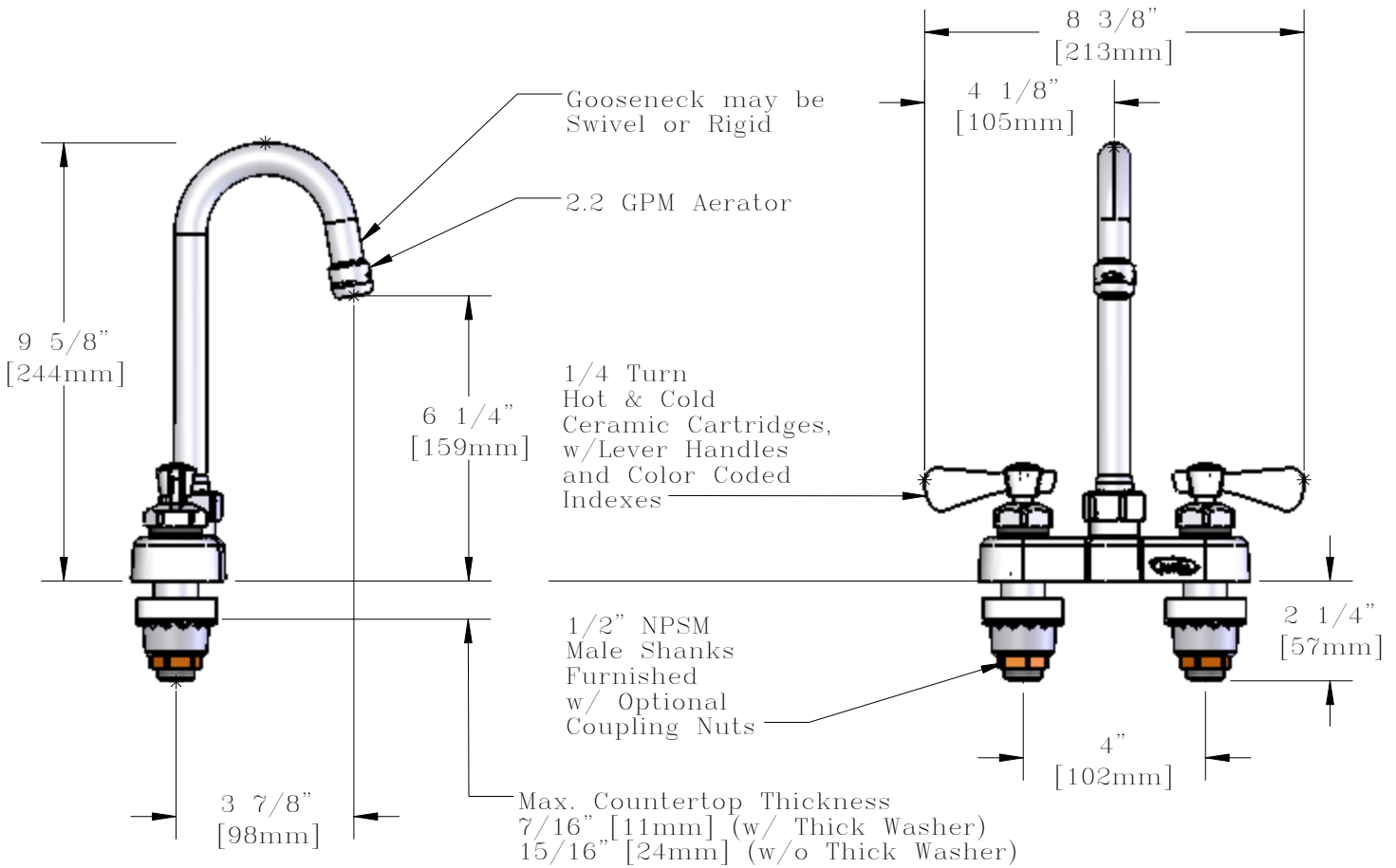

Model Number <b>Q-438YA</b>	Date <b>10/23/2006</b>	Scale <b>1:4</b>	Drawn <b>DHL</b>	Checked <b>JRM</b>	Approved <b>JHB</b>
--------------------------------	---------------------------	---------------------	---------------------	-----------------------	------------------------



Product Specifications:  
**4" Centerset Mixing Faucet, Ceramic Cartridges, Lever Handles, 3 1/2" Gooseneck (GN-A), 2.2 GPM Aerator**



T&S BRASS AND BRONZE WORKS, INC.  
 2 Saddleback Cove, P.O. Box 1088  
 Travelers Rest, South Carolina 29690

Phone: 800.476.4103 Fax: 800.834.3518, Simi Valley 800.423.0750



REG. #A2601  
 ISO #9001

ITEM NO.	SALES NO.	DESCRIPTION
1	Q015383-40	Standard Ceramic Cartridge, Hot
2	Q015384-40	Standard Ceramic Cartridge, Cold
3	Q015973-40	Lever Handle, 1-Pack Kit
4	Q015972-40	Lever Handle, 2-Pack Kit
5	Q015379-40	3 1/2" Gooseneck (GN-A)
6	Q014986-45	Aerator, Female, 2.2 GPM
7	Q016062-45	GN Swivel/Rigid Kit
8	Q015424-40	Shank Hardware

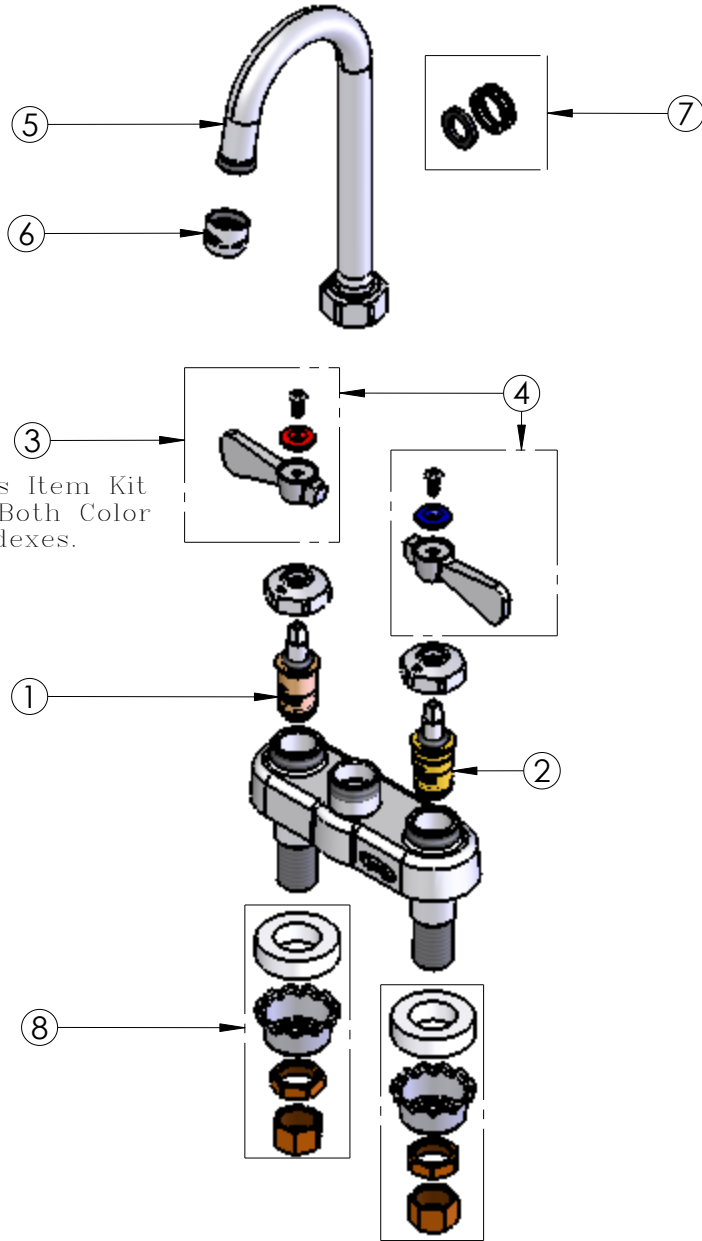

Note: This Item Kit Includes Both Color Coded Indexes.

Model Number Q-438YA	Date 10/23/2006	Scale 1:4	Drawn DHL	Checked JRM	Approved JHB
-------------------------	--------------------	--------------	--------------	----------------	-----------------



Product Specifications:  
**4" Centerset Mixing Faucet, Ceramic Cartridges, Lever Handles, 3 1/2" Gooseneck (GN-A), 2.2 GPM Aerator**



T&S BRASS AND BRONZE WORKS, INC.  
 2 Saddleback Cove, P.O. Box 1088  
 Travelers Rest, South Carolina 29690  
 Phone: 800.476.4103 Fax: 800.834.3518, Simi Valley 800.423.0750



REG. #A2601  
 ISO #9001