

This Space For Architect/Engineer Approval

Job Name \_\_\_\_\_ Date \_\_\_\_\_  
 Model Specified \_\_\_\_\_ Quantity \_\_\_\_\_  
 Customer/Wholesaler \_\_\_\_\_  
 Contractor \_\_\_\_\_  
 Architect/Engineer \_\_\_\_\_

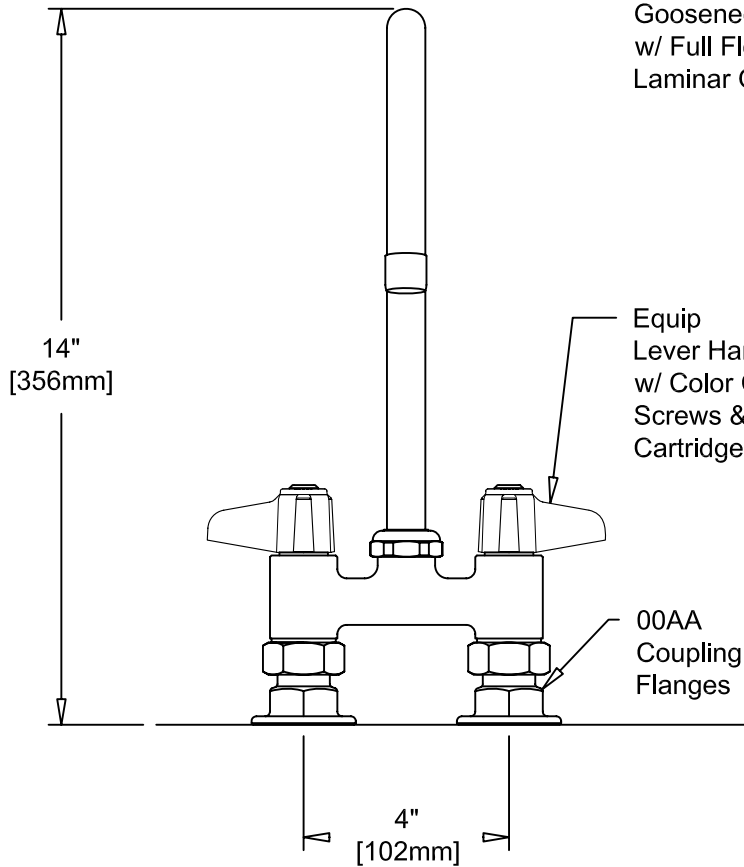

5SP-05  
 Gooseneck  
 w/ Full Flow  
 Laminar Outlet

Equip  
 Lever Handles  
 w/ Color Coded  
 Screws & Ceramic  
 Cartridges

00AA  
 Coupling  
 Flanges

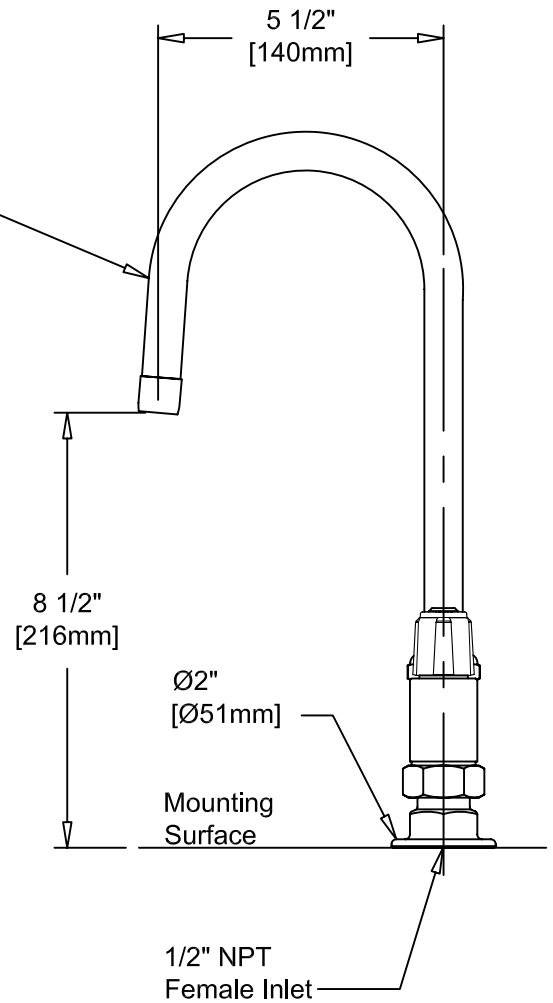
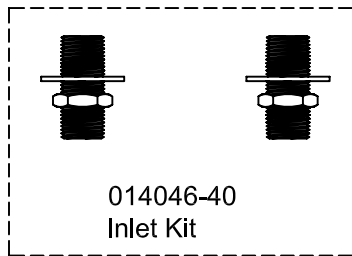

Note: Rough-In Requirement  
 Ø1" [Ø25mm] Holes  
 4" [102mm] On Center

MODEL NUMBER 5F-4DLS05	DATE 02/03/09	SCALE 1:4	DRAWN KJG	CHECKED GEF	APPROVED JHB
---------------------------	------------------	--------------	--------------	----------------	-----------------

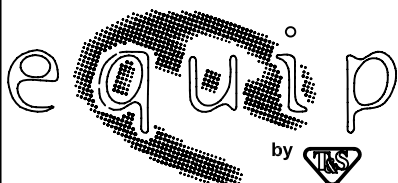

DESCRIPTION

4" Deck Mount Faucet w/  
 5 1/2" Swivel Nozzle &  
 1/2" NPT Inlet Kit

equip Foodservice Accessories  
 P.O. BOX 1088, 2 SADDLEBACK COVE  
 TRAVELERS REST, SOUTH CAROLINA 29690  
 PHONE: 800.891.4808 FAX: 800.868.0084