



T&S BRASS AND BRONZE WORKS, INC.
 2 SADDLEBACK COVE / P.O. BOX 1088 / TRAVELERS REST, SC 29690
 PHONE 800-476-4103 - FAX 864- 834-3518



Model No.
 B-1119
**RELIABILITY
 BUILT IN**

Job Name:

Architect/Engineer Approval:

Notes:

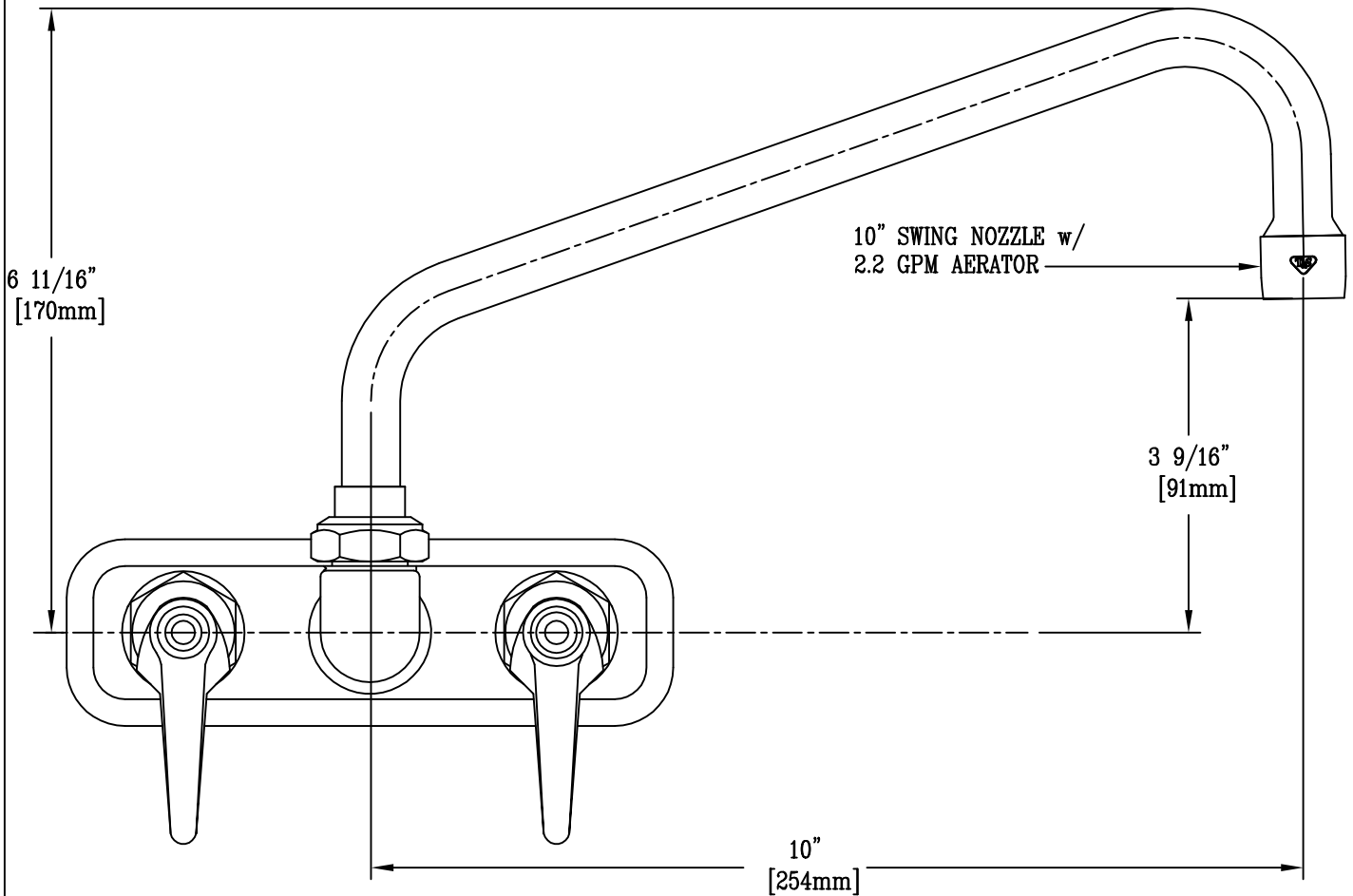
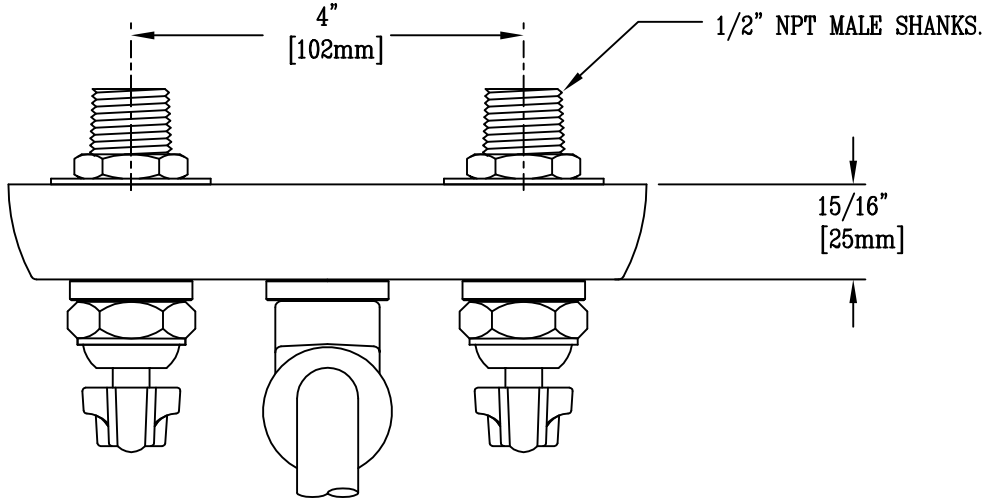

Product Description:
 4" c/c WALL MOUNT WORKBOARD FAUCET WITH 1/2" NPT MALE SHANKS, 10" SWING NOZZLE, 2.2 GPM AERATOR

Drawn:
 WJS
 Approved

Checked
 Date:

Scale:
 1:2