



**T&S BRASS AND BRONZE WORKS, INC.**  
 2 SADDLEBACK COVE / P.O. BOX 1088 / TRAVELERS REST, SC 29690  
 PHONE 800-476-4103 FAX 864-834-3518



Model No.

B-2490

Item No.:

Job Name:

Architect/Engineer Approval:

Notes:

ADJUSTABLE FLOW, VANDAL RESISTANT  
 PUSH BUTTON METERING CARTRIDGE

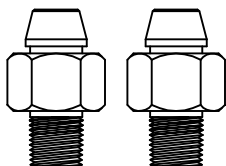
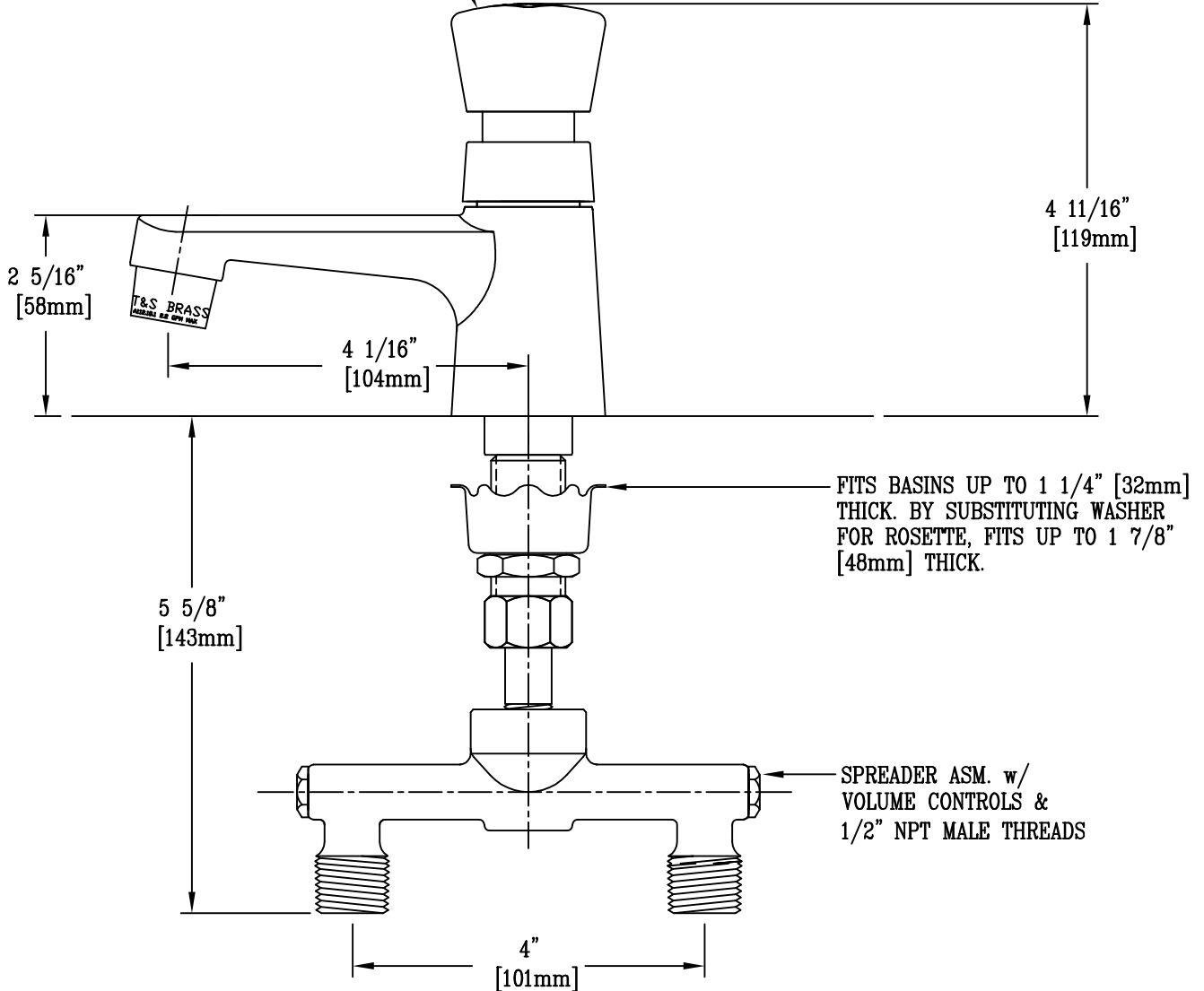

150A TAILPIECE AND NUT FURNISHED FOR OPTIONAL 1/4" NPT CONNECTION

FURNISHED w/ SPANNER BIT



Product Description:

PUSH BUTTON METERING FCT. w/ AERATOR & BELOW COUNTER SPREADER ASSEMBLY

Drawn:

DHL

Approved

JHB

Checked

WJS

Scale:

1 : 2

Date:

12/7/05