

This Space for Architect/Engineer Approval

Job Name _____ Date _____

Model Specified _____ Quantity _____

Customer/Wholesaler _____

Contractor _____

Architect _____

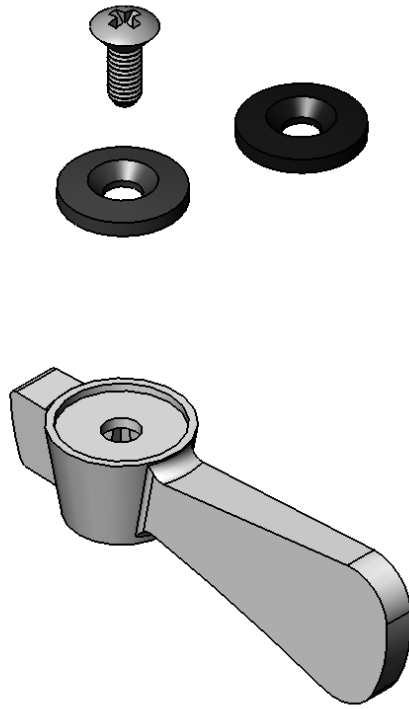

Model Number Q015973-40	Date 3/10/2006	Scale 1:2	Drawn JRM	Checked WJS	Approved JHB
----------------------------	-------------------	--------------	--------------	----------------	-----------------

Product Specifications:
LEVER HANDLE, 1-PACK KIT



T&S BRASS AND BRONZE WORKS, INC.
2 Saddleback Cove, P.O. Box 1088
Travelers Rest, South Carolina 29690
Phone: 800.476.4103 Fax: 800.834.3518, Simi Valley 800.423.0750



REG. #A2601
ISO #9001