



This Space for Architect/Engineer Approval

Job Name _____ Date _____
 Model Specified _____ Quantity _____
 Customer/Wholesaler _____
 Contractor _____
 Architect/Engineer _____

Available Options

Model Suffix #	Description
<input type="checkbox"/> -5A	2.2 GPM VR Aerator
<input type="checkbox"/> -5B	0.5 GPM Aerator
<input type="checkbox"/> -5C	0.5 GPM VR Aerator
<input type="checkbox"/> -5D	2.2 GPM Laminar Flow
<input type="checkbox"/> -VR5C	Complete VR Pkg (0.5 GPM)
<input type="checkbox"/> -VR5A	Complete VR Pkg (2.2 GPM)

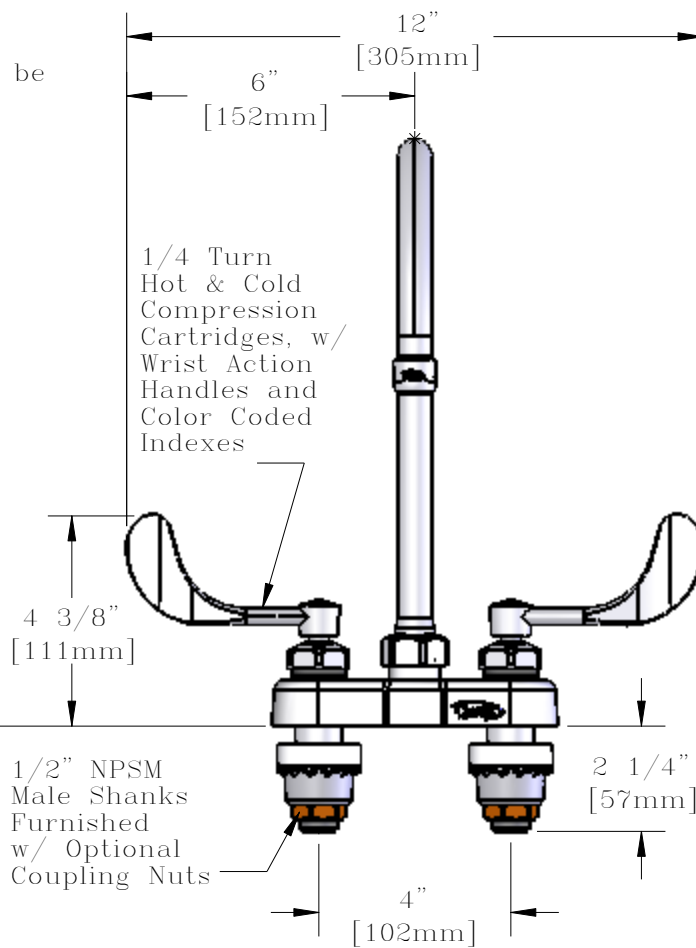
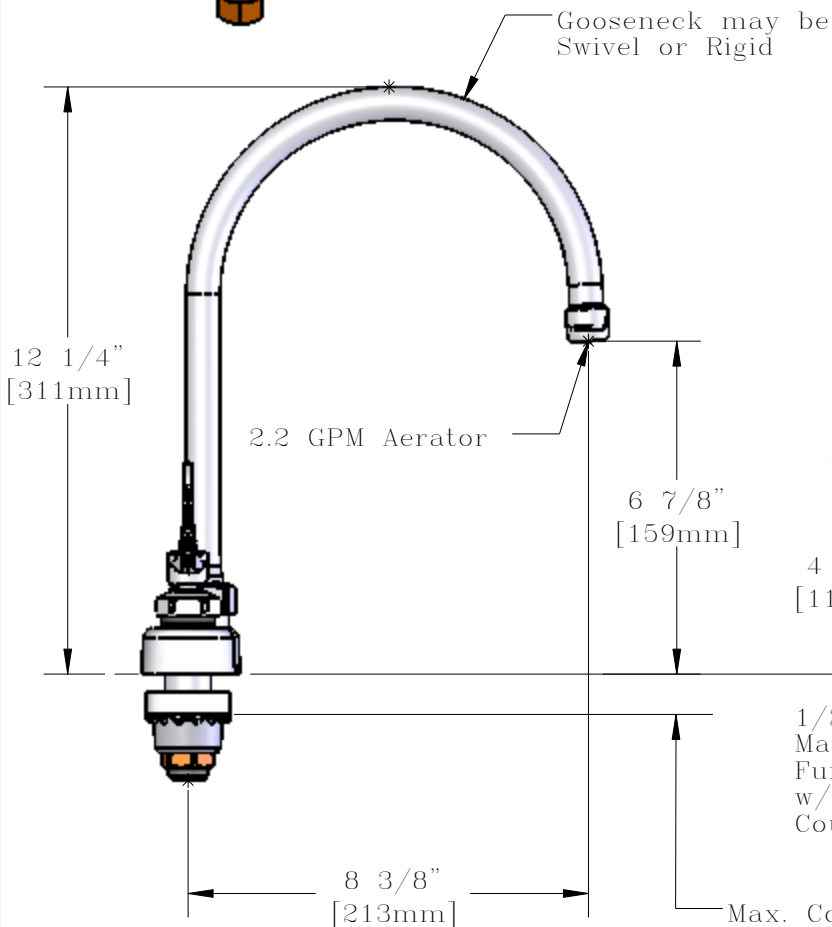
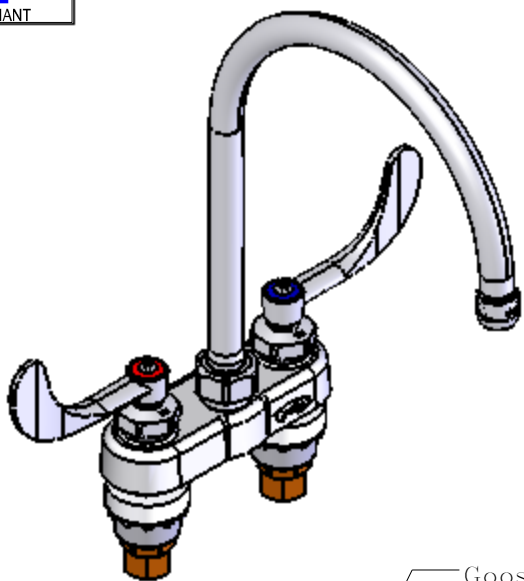

Max. Countertop Thickness
 7/16" [11mm] (w/ Thick Washer)
 15/16" [24mm] (w/o Thick Washer)

Model Number Q-439WC	Date 10/23/2006	Scale 1:4	Drawn DHL	Checked JRM	Approved JHB
--------------------------------	---------------------------	---------------------	---------------------	-----------------------	------------------------



Product Specifications:
**4" Centerset Mixing Faucet, Compression Cartridges,
 Wrist Action Handles, 8" Gooseneck (GN-C),
 2.2 GPM Aerator**



T&S BRASS AND BRONZE WORKS, INC.
 2 Saddleback Cove, P.O. Box 1088
 Travelers Rest, South Carolina 29690

Phone: 800.476.4103 Fax: 800.834.3518, Simi Valley 800.423.0750



REG. #A2601
 ISO #9001

ITEM NO.	SALES NO.	DESCRIPTION
1	Q015387-40	Standard Compression Cartridge, Hot
2	Q015388-40	Standard Compression Cartridge, Cold
3	Q015975-40	Wrist Action Handle, 1-Pack Kit
4	Q015974-40	Wrist Action Handle, 2-Pack Kit
5	Q015377-40	8" Gooseneck (GN-C)
6	Q014986-45	Aerator, Female, 2.2 GPM
7	Q016062-45	GN Swivel/Rigid Kit
8	Q015424-40	Shank Hardware

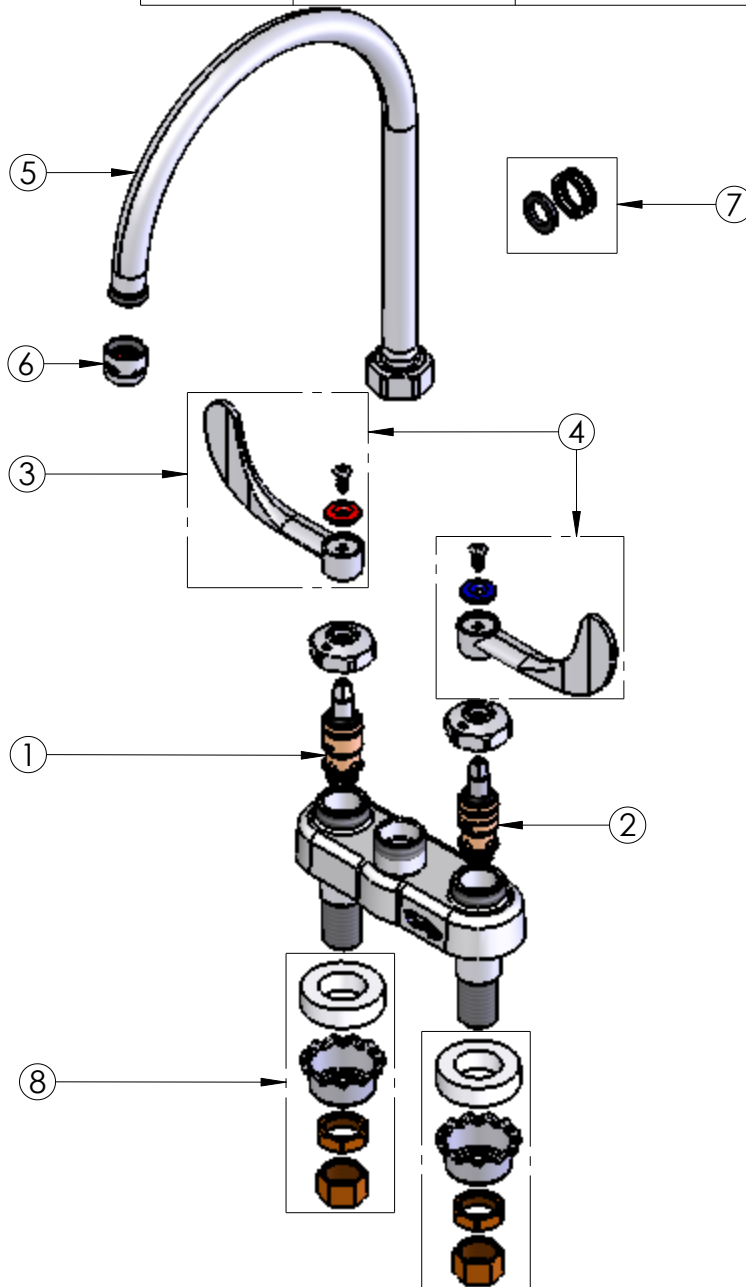

Note: This Item Kit Includes Both Color Coded Indexes.

Model Number Q-439WC	Date 10/23/2006	Scale 1:4	Drawn DHL	Checked JRM	Approved JHB
-------------------------	--------------------	--------------	--------------	----------------	-----------------



Product Specifications:
4" Centerset Mixing Faucet, Compression Cartridges,
Wrist Action Handles, 8" Gooseneck (GN-C),
2.2 GPM Aerator



T&S BRASS AND BRONZE WORKS, INC.
2 Saddleback Cove, P.O. Box 1088
Travelers Rest, South Carolina 29690

Phone: 800.476.4103 Fax: 800.834.3518, Simi Valley 800.423.0750



REG. #A2601
ISO #9001