

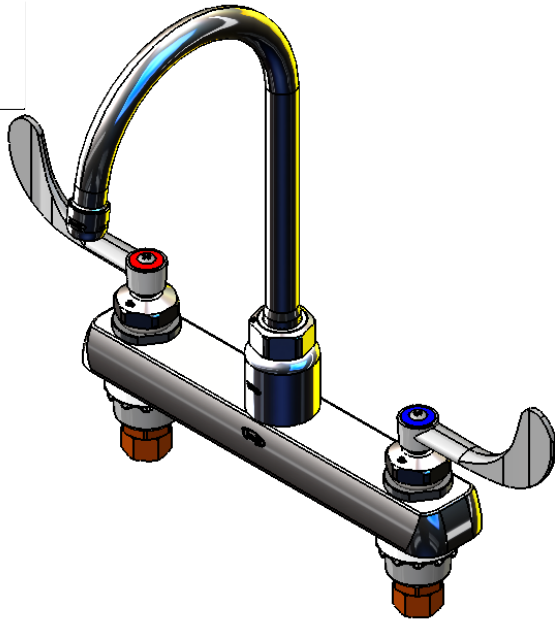

ADA COMPLIANT



*This Space for Architect/Engineer Approval*

Job Name \_\_\_\_\_ Date \_\_\_\_\_

Model Specified \_\_\_\_\_ Quantity \_\_\_\_\_

Customer/Wholesaler \_\_\_\_\_

Contractor \_\_\_\_\_

Architect/Engineer \_\_\_\_\_

*Available Options*

Model Suffix #	Description
<input type="checkbox"/> -5A	2.2 GPM VR Aerator
<input type="checkbox"/> -5B	0.5 GPM Aerator
<input type="checkbox"/> -5C	0.5 GPM VR Aerator
<input type="checkbox"/> -5D	2.2 GPM Laminar Flow
<input type="checkbox"/>	
<input type="checkbox"/> -VR5C	Complete VR Pkg (0.5 GPM)
<input type="checkbox"/> -VR5A	Complete VR Pkg (2.2 GPM)
<input type="checkbox"/>	

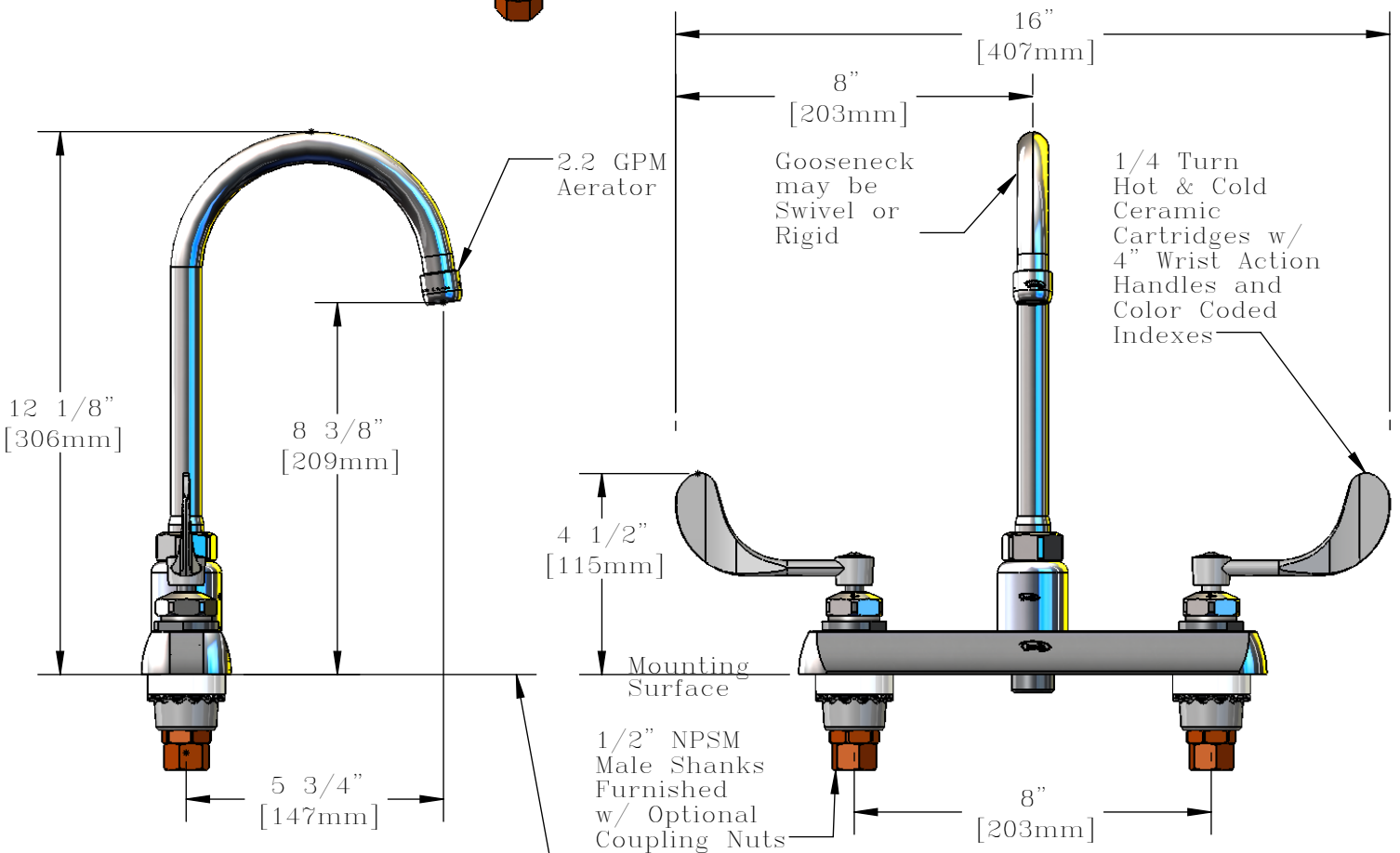

Max. Countertop Thickness  
7/16" [11mm] (w/ Thick Washer)  
15/16" [24mm] (w/o Thick Washer)

Note: Rough-In Requirements  
(3) Ø1" Holes

Model Number <b>Q-838WB</b>	Date <b>04/04/08</b>	Scale <b>1:4</b>	Drawn <b>JRM</b>	Checked <b>GEF</b>	Approved <b>JHB</b>
--------------------------------	-------------------------	---------------------	---------------------	-----------------------	------------------------



Product Specifications:

**8" Exposed Deck Mount Mixing Faucet,  
Ceramic Cartridges, Wrist Action Handles,  
5 3/4" Gooseneck (GN-B) & 2.2 GPM Aerator**



T&S BRASS AND BRONZE WORKS, INC.  
2 Saddleback Cove, P.O. Box 1088  
Travelers Rest, South Carolina 29690

Phone: 800.476.4103 Fax: 800.834.3518, Simi Valley 800.423.0750



REG. #A2601  
ISO #9001

ITEM NO.	SALES NO.	DESCRIPTION
1	Q015383-40	Standard Ceramic Cartridge, Hot
2	Q015384-40	Standard Ceramic Cartridge, Cold
3	Q015975-40	Wrist Action Handle, 1-Pack Kit
4	Q015974-40	Wrist Action Handle, 2-Pack Kit
5	Q015378-40	5 3/4" Gooseneck (GN-B)
6	Q014986-45	Aerator, Female, 2.2 GPM
7	Q016062-45	GN Swivel/Rigid Kit
8	Q015424-40	Shank Hardware

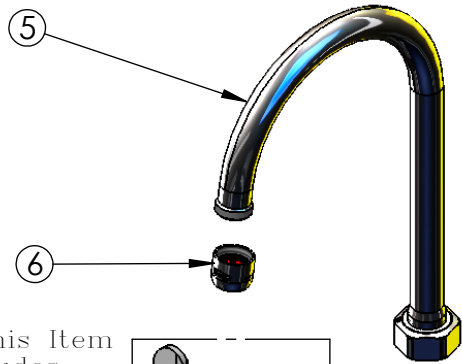

Note: This Item Kit Includes Both Color Coded Indexes.

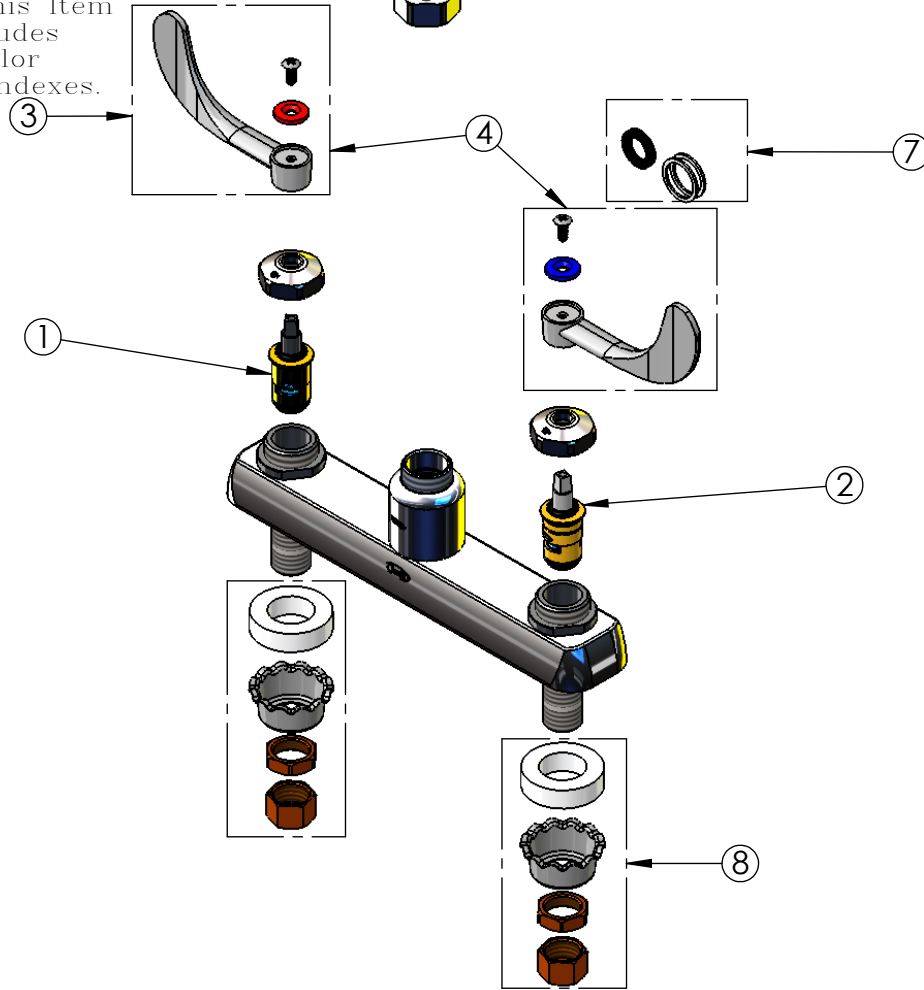

Model Number Q-838WB	Date 04/04/08	Scale 1:4	Drawn JRM	Checked GEF	Approved JHB
-------------------------	------------------	--------------	--------------	----------------	-----------------



Product Specifications:

8" Exposed Deck Mount Mixing Faucet,  
Ceramic Cartridges, Wrist Action Handles,  
5 3/4" Gooseneck (GN-B) & 2.2 GPM Aerator



T&S BRASS AND BRONZE WORKS, INC.  
2 Saddleback Cove, P.O. Box 1088  
Travelers Rest, South Carolina 29690

Phone: 800.476.4103 Fax: 800.834.3518, Simi Valley 800.423.0750



REG. #A2601  
ISO #9001